

# CHEETAH

## RUGGEDIZED CAMERA SERIES

### C5180 CMOS 25 MP Dual CXP-6



#### Imperx: C5180

The C5180 features the ON Semiconductor Python NOIP1xx025KA CMOS image sensor with a native resolution of 5120 x 5120 in an APS-H optical format. The GenICam™ compliant camera delivers up to 44 frames per second in global shutter mode using a dual CXP-6 CoaXPress interface. CMOS technology eliminates smear columns from areas of ultra-bright intensity and specular reflections in uncontrolled lighting applications. The Imperx Cheetah line provides excellent image quality with Imperx proprietary processing. In addition, Imperx puts you in control and gives you full access to raw data without corrections. Using the simple, intuitive Graphical User Interface, you can quickly apply or remove image corrections. Flexibility and image quality make the C5180 suitable for a broad range of diverse and demanding applications. Imperx can help optimize the camera to your exacting requirements.

#### Specifications

Feature	Description	Feature	Description
Interfaces available	2-channel CXP-6 CoaXPress®, USB3, Camera Link® Full (CLF), GigE Vision®	Strobe Output	2 strobes, programmable position and duration
Resolution	5120 x 5120	Pulse Generator	Yes, programmable
Sensor	Python NOIP1xx025KA, CMOS Color/Mono/ENIR	Image Enhancement	Two LUTs: 1 LUT pre-programmed with Gamma 0.45
Sensor Format	23 mm (H) x 23 mm (V) 32.5 mm diagonal APS-H optical format	Data Corrections	Bad pixel correction (static, dynamic) flat field correction, fixed pattern noise
Pixel Size	4.5 µm	Lens Mount	F-Mount (Default), M42, EF Canon (passive or active)
NIR Sensitivity	Mono: 850nm: 18%, 950nm: 6% ENIR: 850nm: 30%, 950nm: 11%	Power	Power over CXP (PoCXP)
Shutter	Global shutter (GS)	Camera Current	Typical: TBD, Maximum: TBD
Fixed Pattern Noise	<0.9 LSB	Size - Width/Height/Length	72.0mm (W) x 72.0mm (H) x 34.7mm (L) – Applies to all interfaces
Digitization	10 bit	Weight	379g
Frame Rate	35.6 fps (10 bit), 44 fps (8 bit)	Vibration, Shock	TBD
Pixel Clock	32MHz to 360MHz (TBD)	Environmental	-40°C to +85°C Operating, -50°C to +90°C Storage
Dynamic Range	59 dB	Humidity	10% to 90% non-condensing
Row Overhead Time (ROT)	Zero	MTBF	>323,000 hours @ 40°C (Telcordia SR-332)
Bit Depth	8, 10 bit	Military Standard	MIL-STD-810F
Analog Gain Control	1x, 1.26x, 1.87x, 3.17x	Regulatory	FCC Part 15 Class A, CE, RoHs
Digital Gain	1x (0dB) to 15.9 (24 dB) with a precision of 0.001x. (AGC available)		
AEC/AGC	Yes		
White Balance	Manual, auto, off		
Shutter Speed	1 µs/step, 40 µs to 1.0 sec		
Exposure Control	Off, internal, external. (AEC available)		
Regions of Interest (ROI)	1 ROI		
Averaging Decimation	1 x 2, 2 x 1, 2 x 2		
Sub-sampling Decimation	1 x 2, 2 x 1, 2 x 2		
Trigger Inputs	External, pulse generator, software		
Trigger Options	Edge, debounce		
Trigger Modes	Internal, external, software		
External Inputs/Outputs	2 IN (OPTO, LVTTTL) / 2 OUT (OPTO, TTL)		

## Imperx: C5180 Applications

The C5180 incorporates a number of unique features tailored to reduce system complexity, maximize interface bandwidth, and expand the usable operational range.

Aerospace • Satellites • Surveillance • Military and Non-Military Ground Vehicles • Ball Grid Array • Printed Circuit Board Inspection • Motion Analysis • Broadcast Television • Telepresence • Unmanned Aerial Vehicles • Machine Vision • Reconnaissance • Aerospace • Intelligent Traffic Systems • Aerial Imaging • Open Road Tolling Systems • Situational Awareness

## Absolute Quantum Efficiency

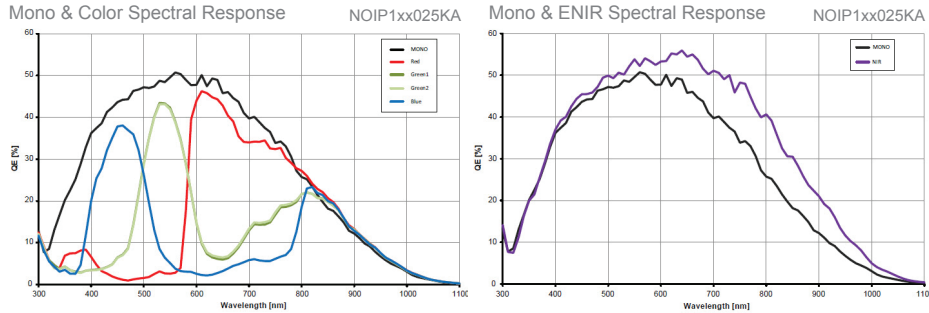

## Dimensions

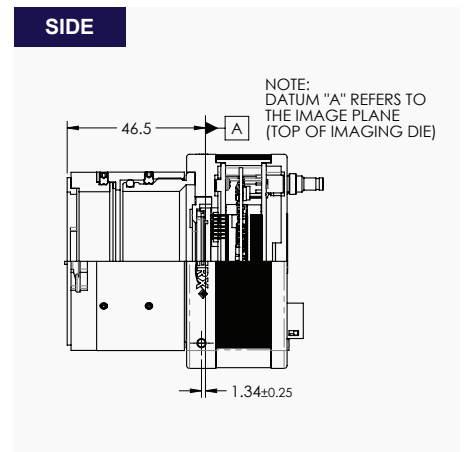
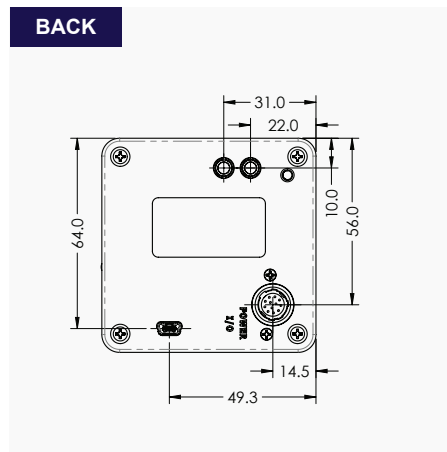
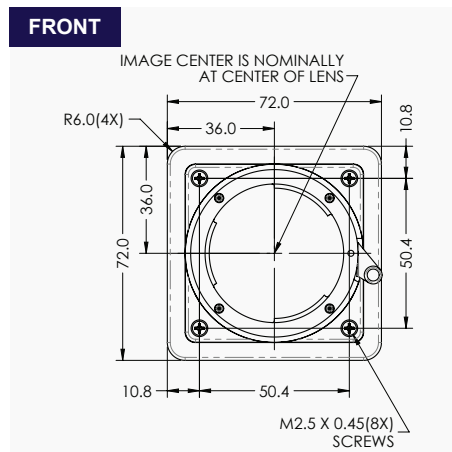

## Ordering Information

Interface Available	
2-channel CXP-6	Camera Link Full (CLF)
CoaXPress	
USB3	GigE Vision

Sensor Types available	
Monochrome	
Bayer Color	
NIR	

Lens Mounts	
F-Mount (Default)	
M42	
EF Canon	

  

Accessories (Sold separately)	
PS12V04A-Power Supply w/ 1 input and 1 output	

## GenICam Compliant Camera Configurator

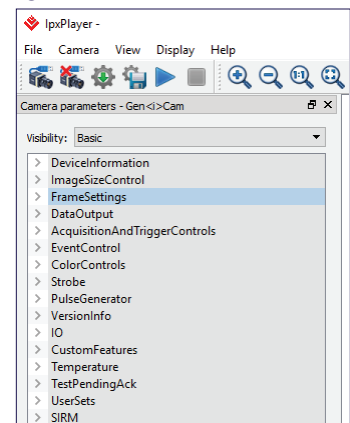

## Hirose Connectors

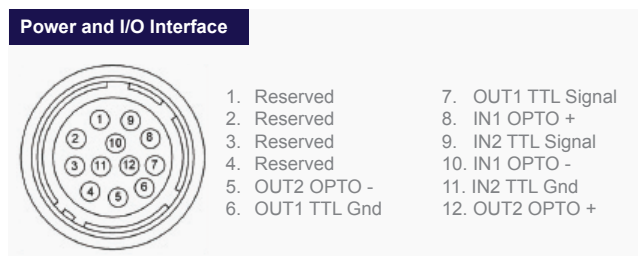

Quality Management System ISO 9001:2015 Registered  
 Environmental Management System ISO 14001:2015 Registered  
 DDTC Registered (Directorate of Defense Trade Controls, US Department of State)



IMPERX 6421 Congress Ave., Boca Raton, FL 33487, USA  
 Tel: +1-561-989-0006. Email: sales@imperx.com

[WWW.IMPERX.COM](http://WWW.IMPERX.COM)

Technical data has been fully checked, but accuracy of printed matter is not guaranteed. Subject to change without notice. Copyright 2017.